

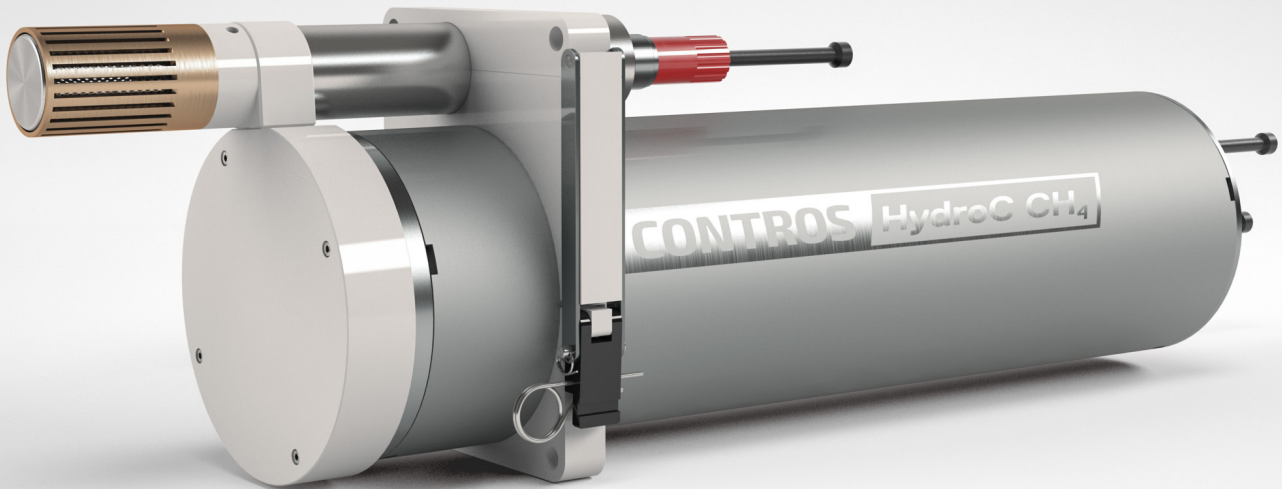

KONGSBERG

CONTROS HydroC CH₄



ACCURATE, LONG-TERM STABLE METHANE SENSOR

The CONTROS HydroC[®] CH₄ sensor is a unique underwater methane sensor for in-situ and online measurements of CH₄ partial pressure ($p\text{CH}_4$). The versatile CONTROS HydroC[®] CH₄ provides the perfect solution for the monitoring of background CH₄ concentrations and for long-term deployments.

Operating principle

Dissolved CH₄ molecules diffuse through a custom made thin film membrane into the internal gas circuit leading to a detector chamber, where the CH₄ concentration is determined by means of Tunable Diode Laser Absorption Spectroscopy (TDLAS). Concentration dependent laser light intensities are converted into the output signal from calibration coefficients stored in firmware and data from additional sensors within the gas circuit.

High accuracy and stability

Due to their narrow line-width, the Tunable Diode Laser Detectors have a high accuracy and an ideal selectivity for methane molecules. In addition, they feature a large dynamic range covering background partial pressures up to 40 matm. All detectors are subject to an individual calibration and an in depth quality check in our QA lab before they are integrated into our sensors. The quality of the calibration is then verified individually in calibration tanks. The sensor is stable over a long time as the detector tunes the laser to CH₄ absorbing and non-absorbing wavelengths for each measurement thus compensating for potential drift influences.

Accessories

A wide range of available accessories ensures that each of the CONTROS HydroC[®] CH₄ sensors can be adapted to meet customers' requirements. Underwater pumps and different flow head designs are the most popular options, which ensure fast response times. An antifouling head is used under conditions with significant biofouling pressure. The internal data logger can be used in conjunction with the CONTROS HydroC[®]'s flexible power management features and the CONTROS HydroB[®] battery packs to conduct unattended long-term deployments.



FEATURES

- High accuracy and low detection limit of background concentration
- Large measuring range
- Optimal long-term stability
- Ideal methane selectivity
- Non-consuming CH₄ measurement
- Very robust, can be used in water depths up to 3000 meters
- User-friendly 'Plug & Play' principle; all required cables, connectors and software are included

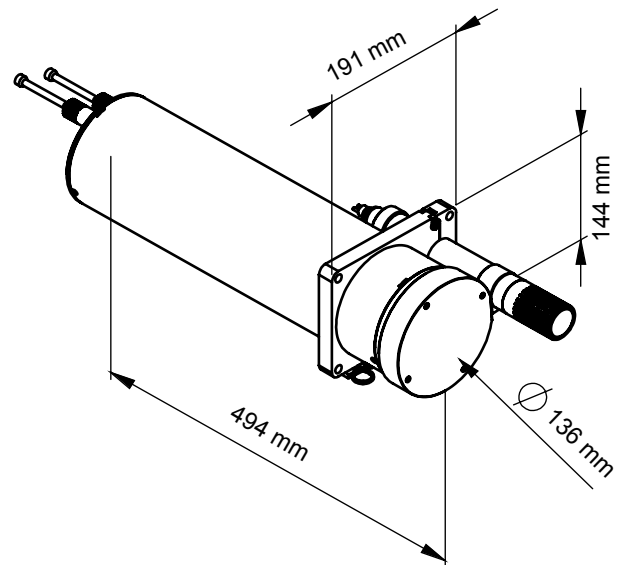

TECHNICAL SPECIFICATIONS

CONTROS HydroC CH₄

- Detector TDLAS - Tunable Diode Laser Absorption Spectroscopy
- Measuring range 0- 40,000 µatm
- Detection limit < 1 µatm
- Weight 5.5 kg in water, 12.5 kg in air
- Dimensions 136 x 494 mm (without connector)
136 x 528 mm (with connector)
- Operational depth 3,000 m
- Temperature ranges -2°C to +35°C
(other ranges available)
- Resolution < 0.01 µatm
- Accuracy ±2 µatm or ±3 %, whichever is greater
- Connector SUBCONN MCBH-M Titanium 8-pin
(other connectors on request)
- Supply voltage 12 V - 30 V
- Power consumption Approx. 690 mA @ 12 V and additional
8 W with SBE-5T external pump
(approx. values for standard configuration
at 20°C ambient temperature)
- Data interface RS-232C
- Data format ASCII

SOFTWARE

CONTROS DETECT® incl. real-time data visualization, setting of sensor parameters, download data from internal data logger and sleep mode function

HARDWARE REQUIREMENTS

Win 7 32 Bit, 200 MB free disk space,
Dual Core CPU with 2GB RAM

OPTIONS

- Available temperature ranges for reduced power consumption
-2°C to +30°C
-2°C to +20°C
-2°C to +8°C
- Analogue output: 0 V - 5 V
- RS-485 data interface
- Internal data logger
- External battery packs
- ROV and AUV installation packages
- Profiling and mooring frames
- External pump (SBE-5T or SBE-5M)
- Easy deployment together with a CONTROS HydroFlash® O₂

Specifications subject to change without any further notice.

KONGSBERG MARITIME
Switchboard: +47 815 73 700
Customer support: +47 33 03 24 07
E-mail sales: km.sales@km.kongsberg.com
E-mail support: km.support@kongsberg.com

km.kongsberg.com



KONGSBERG